

SmartHome™



INDOOR/OUTDOOR WIRELESS CAMERA SYSTEM

Includes: Video/Audio Camera Transmitter & Monitor/Receiver



Questions? Call 1-800-GE LIGHT
Made in China for
GE Home Electric Products, Inc.
Nela Park, Cleveland, OH 44112
Desc.: GESECTVBW-2

USER'S GUIDE

8.50"

Congratulations on your purchase of the GE SmartHome™ **Wireless Camera System (WCS)**. The WCS is a combined wireless camera and video monitor/ receiver, an ideal combination for monitoring the porch, watching the yard, pool, pets or the baby. It is also suited to many small business applications.

FEATURES

- 2.4GHz wireless technology
- Plug 'n' play installation
- High resolution black and white video camera with motion detection
- Built-in microphone transmits sound from camera to monitor
- High quality audio and video components for long life
- Supports up to 3 cameras
- Durable weather resistant camera construction
- Manual or auto switching between cameras
- AC or battery operation (batteries not included)
- IR LEDs for night vision
- Photocell sensor to automatically turn on night vision when needed

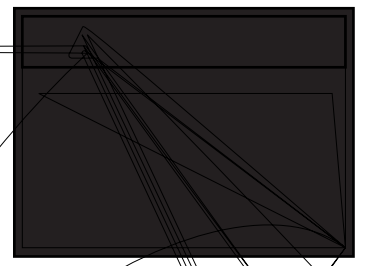

The wireless camera can also be operated with the GE Rechargeable Battery Pack GESECBATZ (sold separately) for complete portability and extended battery life.

SYSTEM CONTENTS

Identify all parts before proceeding with installation.

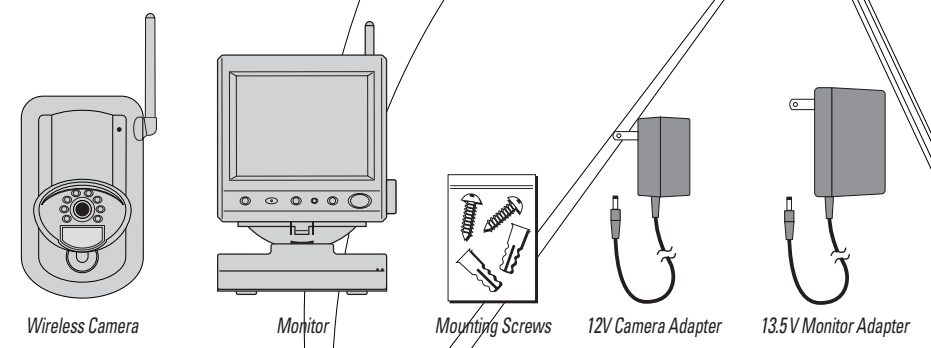

THINGS TO CONSIDER BEFORE INSTALLATION

For best performance, follow these simple guidelines:

- Camera(s) should be installed between 8 and 13 feet above the area to be monitored
- The Camera should be aimed accordingly to optimize viewing area
- For best transmission, avoid installations where there are thick walls or major obstructions between the Camera and Monitor

5.50"

5.50"

INSTALLATION Decide whether the Camera will be wall-mounted or desk-mounted.

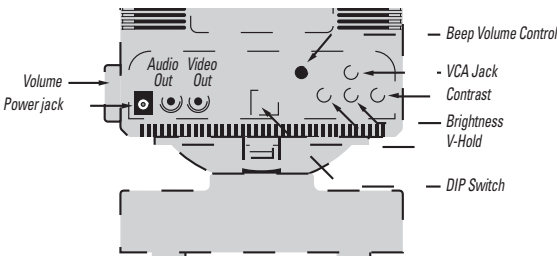
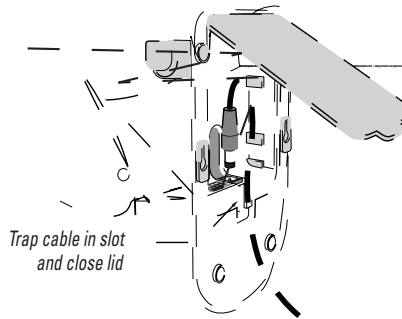
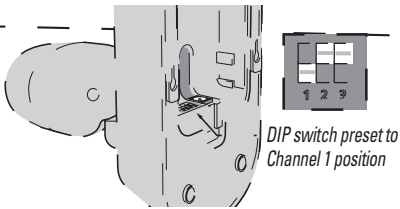
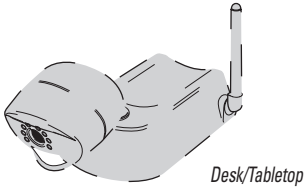

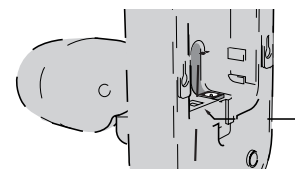
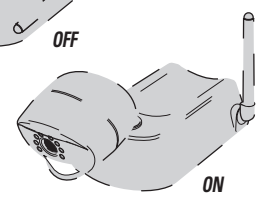
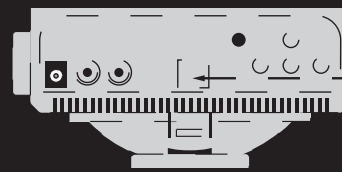

Camera 1's
DIP Switch



Camera 2's
DIP Switch
(if using)



Camera 3's
DIP Switch
(if using)

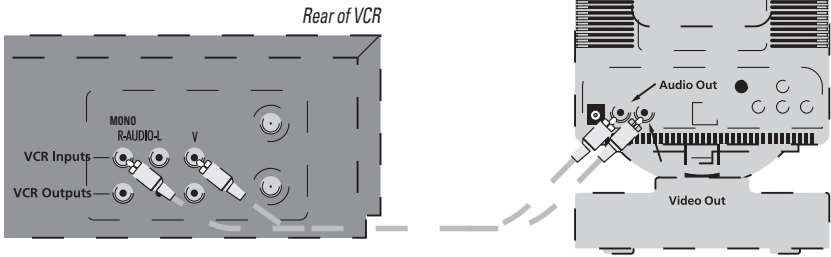

SYMPTOM

REMEDIES

No camera picture

1. Check all connectors. Make sure camera(s) and monitor are switched ON.
2. Ensure camera(s) and monitor are set to correct channel(s).
3. Make sure camera is within range of monitor (receiver).

Blank monitor

1. Make sure monitor is switched ON.
2. If using AC adapter, make sure it is plugged in.
3. If using batteries, make sure they are installed correctly, or try replacing them.

Interference on camera picture

1. Make sure each camera (transmitter) is within range, and that no large obstructions are blocking the signal.
2. Try repositioning the camera, monitor or both to improve the reception quality.
3. If a camera is positioned close to the monitor (receiver), point antenna away from the monitor.
4. Reposition other nearby equipment transmitting on the 2.4 GHz frequency.

Audio problems

1. Ensure the volume is turned up sufficiently on the monitor.
2. Make sure the sound is within the microphone range.
3. If the unit emits a loud wailing sound (feeds back), try moving the camera away from the monitor or angle the monitor differently.

DRILLING TEMPLATE FOR WALL MOUNTING CAMERA(S)

For wall-mounting Camera(s), drill two holes using a 1/4" drill bit and the template below. Insert supplied wall anchors into holes and secure camera to wall with supplied screws.

